

Senovol PID sensors are designed for the detection of a wide variety of volatile organic compounds (VOCs). In general, any compound with an ionization energy (IE) lower than that of the lamp photons can be measured. Based on its proprietary ultraviolet (UV) lamp technology, Senovol PID sensors have the advanced features of high UV outputs, and long lamp life spans.

### Product Dimensions

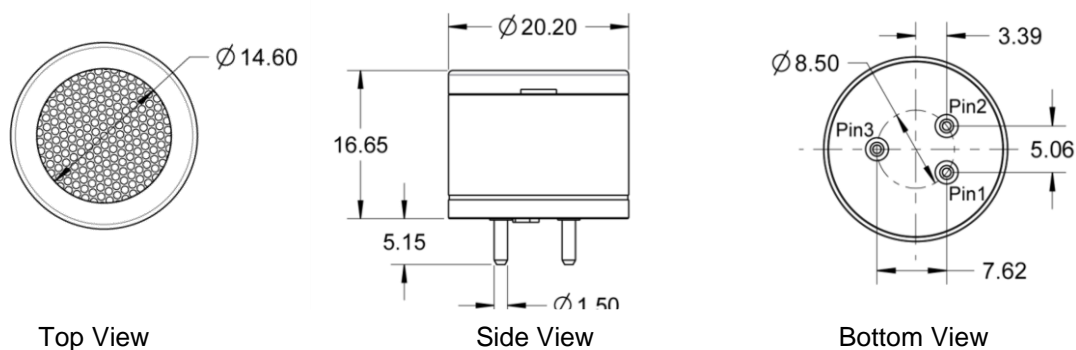

All dimensions in mm

### Performance

Photon energy	9.8 eV
Measurement range	0 ~ 2,000 ppm benzene
Resolution	1 ~ 500 ppb benzene
Response time (T90)	< 5 seconds
Baseline shift (20°C)	70 ± 15 mV
Linearity	linear from 0.045 ~ 2.5 V

### Electrical

Supply voltage	3.2 ~ 5.5 V
Working current	< 35 mA at 5 V
Output signal	0.045 ~ 2.5 V

### Mechanical

Enclosure	Stainless steel
Weight	15 grams

### Environmental

Temperature range	-20°C ~ +50°C
Pressure range	1 atm ± 10%
Humidity range	0 % ~ 99 %RH Non-condensing

### Life Time

Storage Temp	0 °C ~ 30 °C
Operating lifetime	5 years (excluding lamp and electrodes)
Typical lamp life	10,000 hours
Storage life	2 years in original packaging
Warranty	12 months

### Approvals

CE  
*IECEX and ATEX approvals available upon request*

### Installation

The output signals from the sensor pins are different. Inappropriate use of the pins in product design will affect the sensor functionality. Exposure to high concentrations of solvent vapors should be avoided under any condition. Mechanical overstress may cause deformation of the sensor enclosure and damage the internal components including the lamp. If the sensor is used in extreme environmental conditions, please contact us for more details.

**Pin Out Details**    Pin 1 – VCC    Pin 2 – GND    Pin 3 – VOUT

## Product Selection

Product Name	Part Number	Measurement Range	Photon Energy	Resolution	Sensitivity	Response Time
4PID-10 (9.8eV)	PID-098S-0100	0 ~10 ppm	9.8 eV	1 ppb	> 100 mV/ppm	< 5 s
4PID-20 (9.8eV)	PID-098S-0200	0 ~ 20 ppm	9.8 eV	2 ppb	> 60 mV/ppm	< 5 s
4PID-50 (9.8eV)	PID-098S-0500	0 ~ 50 ppm	9.8 eV	3 ppb	> 30 mV/ppm	< 5 s
4PID-100 (9.8eV)	PID-098S-1000	0 ~100 ppm	9.8 eV	5 ppb	> 15 mV/ppm	< 5 s
4PID-200 (9.8eV)	PID-098S-2000	0 ~ 200 ppm	9.8 eV	50 ppb	> 5 mV/ppm	< 5 s
4PID-2000 (9.8eV)	PID-098S-2001	0 ~ 2,000 ppm	9.8 eV	500 ppb	> 0.5 mV/ppm	< 5 s

## Note

The performance data in this document is taken by applying benzene to the PID sensor using Senovol lab testers. The PID sensor may perform differently if gases other than benzene are used.

## Sensitivity Temperature Data

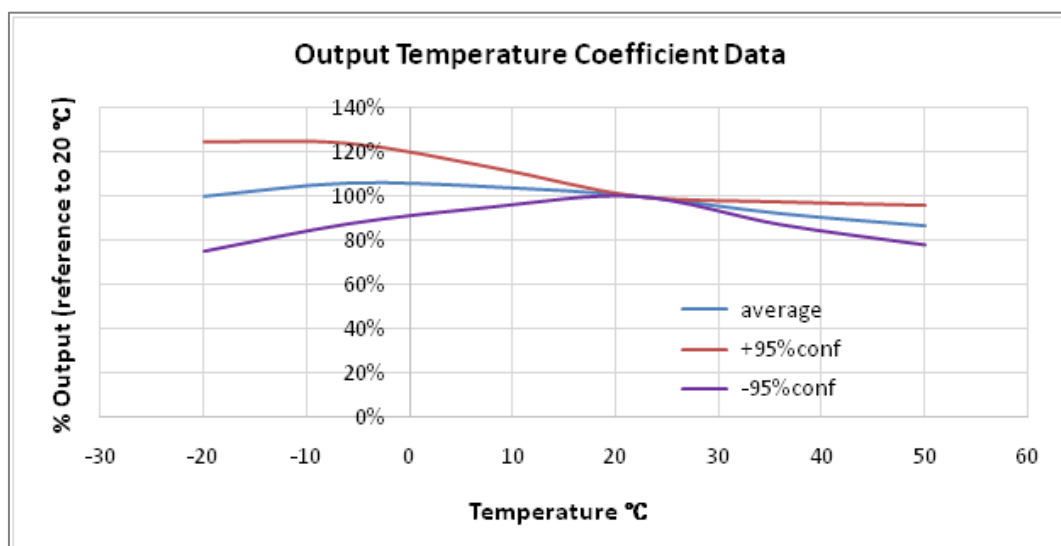

## Safety Note

If the sensor is used in certain instruments for life critical applications, it is required to read the instrument user's guide carefully and comply with the calibration procedures by using the certified target calibration gas before each use. Failure to do so may cause serious injury and/or fatality. It is highly recommended for customers to validate the sensor performance using this document as a reference for their product designs or applications.